

Installation Instructions

I - Sheet Number WTBF07 Rev.A

WeatherTech®
*Easy-On™ Stone & Bug
D e f l e c t o r*

Important Safety Information



- CAUTION - Before driving, ensure that the hood shield is properly anchored to vehicle.
- Do not use automatic “brush-style” car washes.
- Do not use cleaning solvents of any kind.
- Periodically check all components for tightness.

Contents **NOTE:** Actual product may vary from illustration.



Hood Shield



Bump On x4



Alcohol Pad x2

Tools Required



Car Wash Supplies



Clean Towel

Preparation Before Painting / Installation

- A trial fit is recommended to ensure proper positioning and fit.
- Check fit of parts before painting as we will not accept the return of modified or painted parts.
- Wash your vehicle's hood to remove any debris and/or dirt.
- Dry the hood with a clean towel.

Care and Cleaning

- Wash only with mild soap & dry with a clean cloth.

Installation Steps

NOTE: Actual application may vary slightly from illustrations.

Alcohol Pad

Clean mounting surface with alcohol pad.

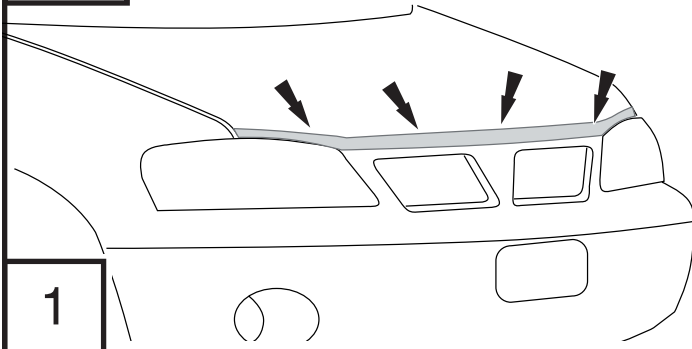

1

Peel back 2" of tape liner from back of hood shield at each end of bottom flange.

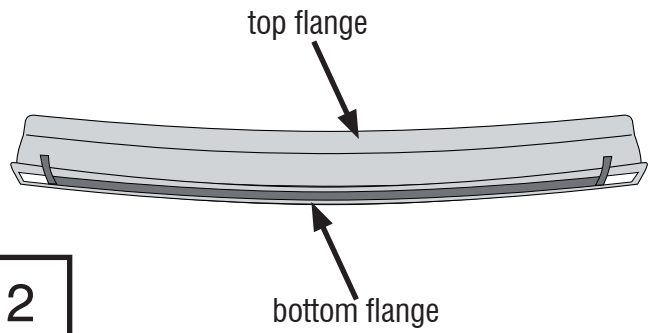

2

Align Hood Shield center point with center of hood.

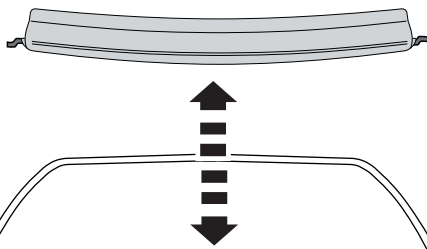

3

Press on exposed tape to adhere to hood. Remove remainder of tape lining by pulling on the free ends.

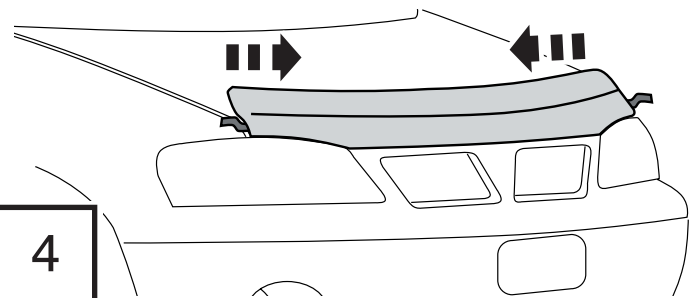

4



Press firmly along tape flange to secure hood shield to vehicle hood.

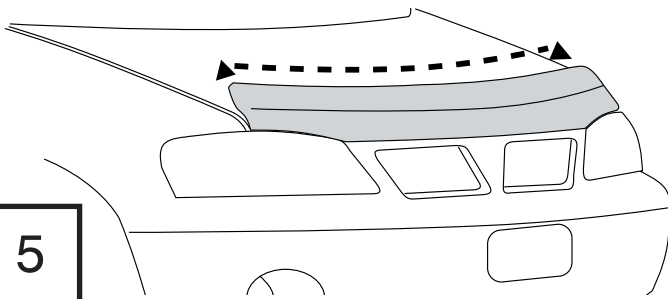

5



Apply bump ons to surface of hood.

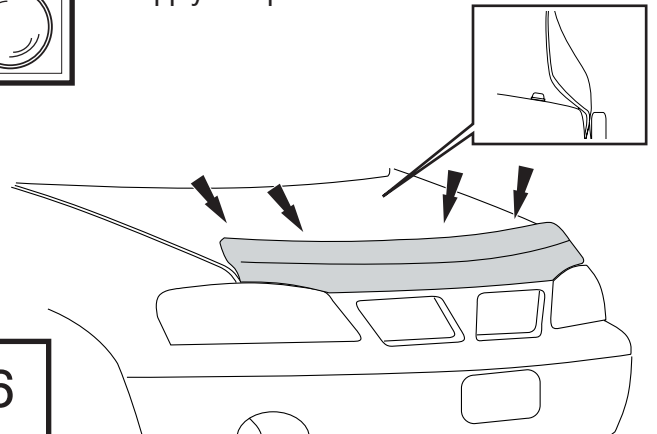

6

MacNeil

AUTOMOTIVE
PRODUCTS LIMITED
2435 WISCONSIN STREET
DOWNERS GROVE, IL 60515

PHONE (630) 769-1500 FAX (630) 769-0300
(800) 441-MATS (6287)

INTERNET ADDRESS: <http://www.macneilauto.com>

WeatherTech® WeatherTech® WeatherTech® WeatherTech® WeatherTech®
FRONT MOUNT CARBON FIBER BUMPS BUMP-ONS BUMP-ONS BUMP-ONS BUMP-ONS

WeatherTech® Easy-On™ Stone & Bug D e f l e c t o r

Informations importantes concernant la sécurité



- ATTENTION – Avant de conduire, s'assurer que le pare-insectes est solidement assujétié sur le véhicule.
- Ne pas utiliser les stations de lavage de voitures à brosses.
- Ne pas utiliser de solvants.
- Vérifier régulièrement le serrage des composants.

Contenu

NOTE: Le produit réel peut changer de l'illustration.

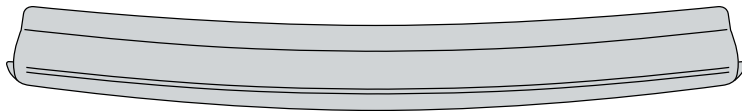

Pare-insectes



Butoirs (4)



Tampons à l'alcool (2)

Outils nécessaires



Fournitures pour lavage de voiture

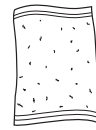

Serviette propre

Préparation pour la peinture/l'installation

- Il est recommandé de procéder à un essai pour s'assurer que le positionnement et l'ajustement sont corrects.
- Vérifier l'ajustement des pièces avant peinture, car nous n'acceptons pas le retour de pièces modifiées ou peintes.
- Laver les glissières de glaces de la portière du véhicule pour éliminer toute poussière et tous débris.
- Sécher les glissières avec une serviette propre.

Entretien et nettoyage

- Laver exclusivement avec de l'eau savonneuse et sécher avec un chiffon propre.

Étapes d'installation

REMARQUE : La méthode d'application peut être légèrement différente de celle représentée par les illustrations.

Alcohol
Pad

Nettoyer la surface de montage à l'aide
d'un tampon à l'alcool.

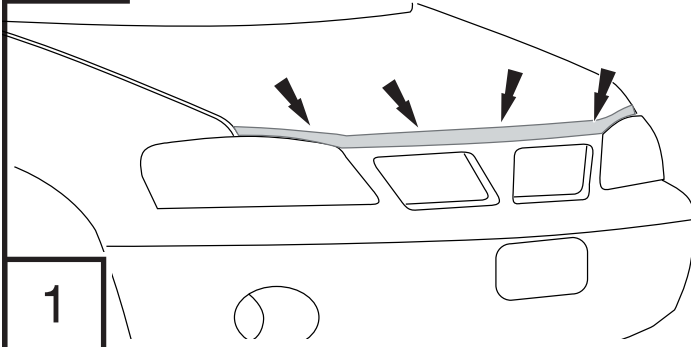

1

Décoller environ 5 cm (2 po) de protection d'adhésif de
l'arrière du pare-insectes, à chaque extrémité du rebord
inférieur.

rebord supérieur

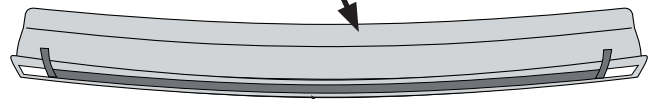

2

Aligner le point central du pare-insectes et le
centre du capot.



3

Appuyer sur la partie exposée du ruban adhésif
pour le faire adhérer au capot. Retirer le reste de la
protection d'adhésif en tirant sur les extrémités libres.

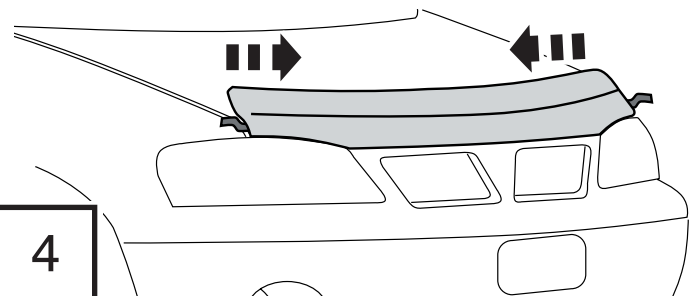

4



Appuyer fermement tout le long du rebord
du ruban adhésif pour fixer le pare-insectes
sur le capot du véhicule.

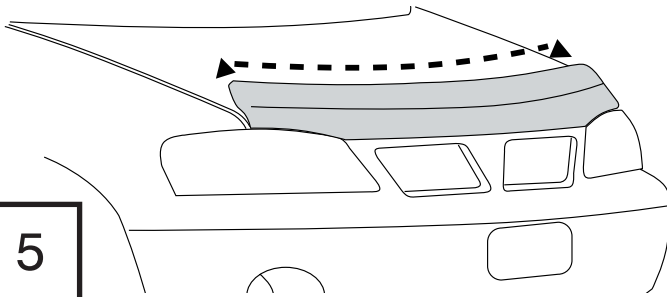

5



Appliquer les butoirs
sur le capot.

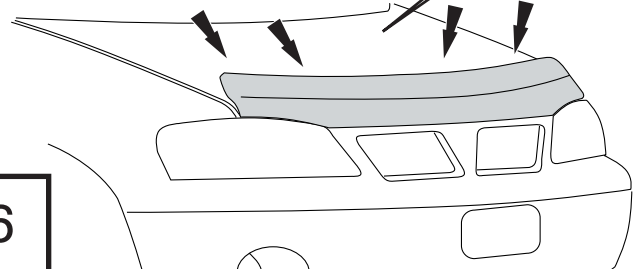
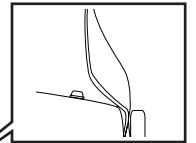

6

MacNeil

AUTOMOTIVE
PRODUCTS LIMITED
2435 WISCONSIN STREET
DOWNERS GROVE, IL 60515

PHONE (630) 769-1500 FAX (630) 769-0300
(800) 441-MATS (6287)

INTERNET ADDRESS: <http://www.macneilauto.com>

WeatherTech® WeatherTech® WeatherTech® WeatherTech® WeatherTech®

WeatherTech® Easy-On™ Stone & Bug Deflector

Información importante de seguridad



- PRECAUCIÓN - Antes de conducir, asegúrese de que la Cubierta para capó esté correctamente anclada al vehículo.
- No utilice servicios automáticos de limpieza de vehículos que utilizan cepillos.
- No utilice limpiadores al solvente de ningún tipo.
- Compruebe periódicamente que todos los componentes estén ajustados.

Contenido

NOTA: El producto real puede variar de la ilustración.

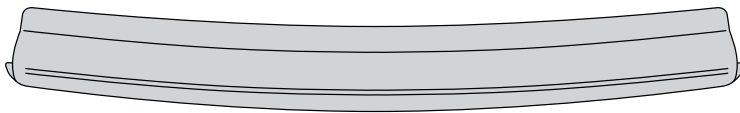

Cubierta para capó

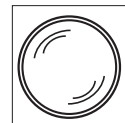

Soporte x 4



Paño esterilizado x2

Herramientas necesarias



Equipo de limpieza de vehículos

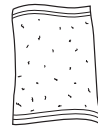

Toalla limpia

Preparación antes de pintar o instalar

- Se recomienda realizar un ajuste de prueba para asegurar el posicionamiento y ajuste correctos.
- Compruebe que las piezas se ajusten correctamente antes de pintarlas, ya que no aceptaremos la devolución de piezas modificadas o pintadas.
- Lave los canales de la ventanilla del vehículo para quitar los desechos y la suciedad.
- Seque los canales de la ventanilla con una toalla limpia.

Cuidado y limpieza

- Limpie solamente con agua jabonosa tibia y seque con un paño limpio.

Pasos de instalación **AVISO:** La colocación real puede variar levemente con respecto a las ilustraciones.

Alcohol Pad

Limpie la superficie de colocación con un paño esterilizado.

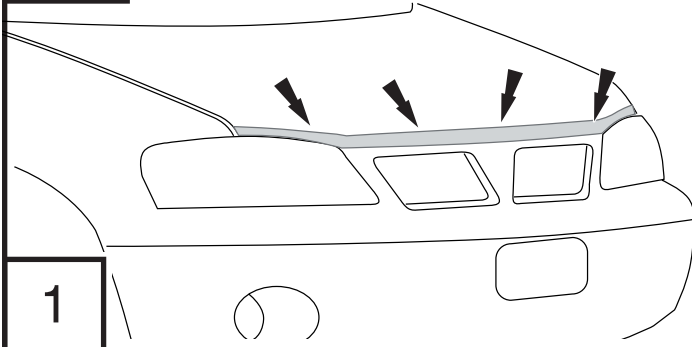

1

Retire 2 pulgs. de cinta protectora de la parte posterior de cubierta para capó en cada uno de los extremos del reborde inferior.

reborde superior

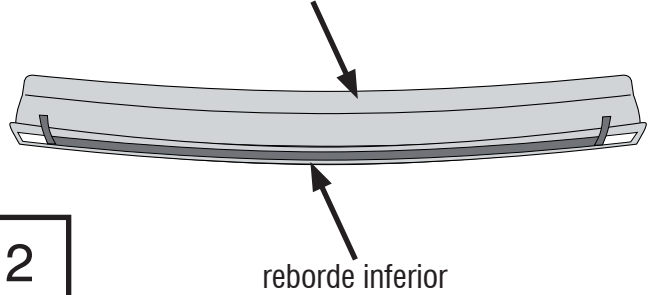

reborde inferior

2

Alinee el centro de la cubierta para capó con el centro del capó.

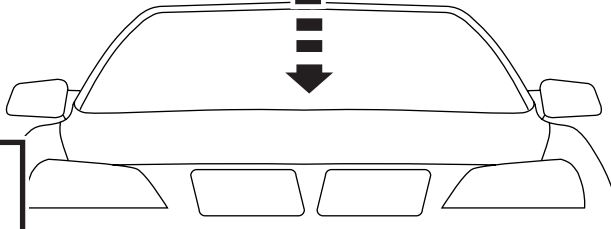

3

Presione sobre la cinta expuesta para fijar al capó. Retire la cinta protectora restante tirando de los extremos libres.

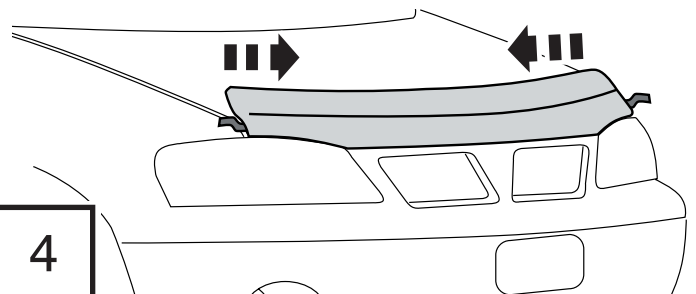

4



Presione firmemente sobre el reborde de la cinta para fijar la cubierta para capó al capó del vehículo.

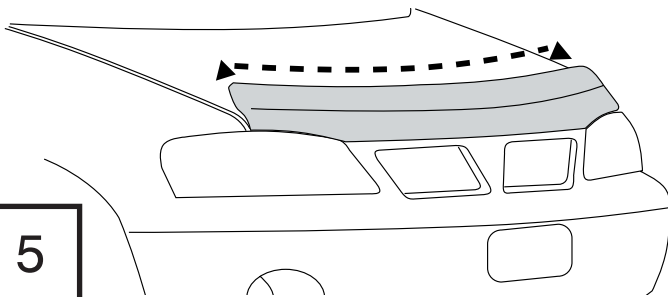

5



Coloque los soportes en la superficie del capó.

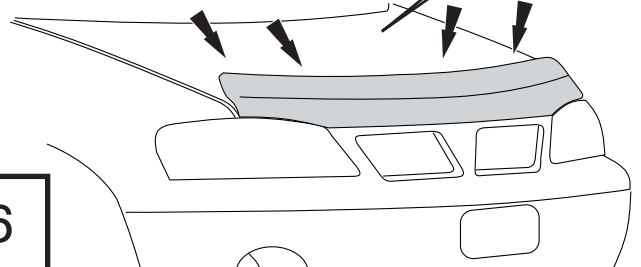
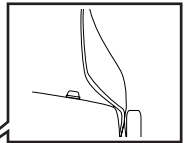

6

MacNeil

AUTOMOTIVE
PRODUCTS LIMITED
2435 WISCONSIN STREET
DOWNERS GROVE, IL 60515

PHONE (630) 769-1500 FAX (630) 769-0300
(800) 441-MATS (6287)

INTERNET ADDRESS: <http://www.macneilauto.com>

WeatherTech WeatherTech WeatherTech WeatherTech WeatherTech